

## Trencher™

### Submersible Dewatering Pump



#### Features

- High abrasive resistance resin Vortex impeller
- Double mechanical seal
- Auto reset thermal protector
- Auto version for small pit usage
- Oil free motor
- Ability to pump down to 84mm
- Compact light design

#### Application

- Hire fleets
- Cellars & basements
- Civil construction
- Quarries & mining
- De-watering

#### Dimensions (mm)

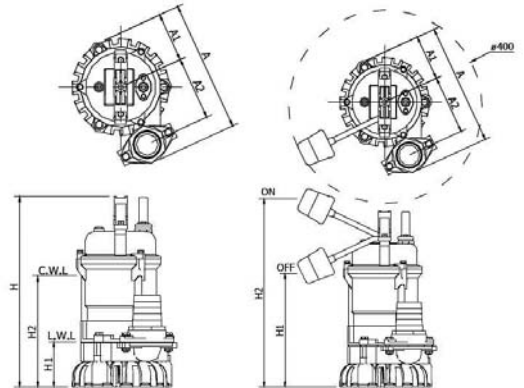

#### Specifications

Model	Rated			Maximum			Cable	Weight			
	kW	AMP	W	mm	Inch	Head			Capacity	Head	Capacity
						M	LPM	M	LPM	M	kg
T400 110V*	0.4	6	400	50	2"	8	110	12	220	10	13
T400 230V*	0.4	3	400	50	2"	8	110	12	220	10	13.3
T750 110V*	0.75	11	750	50(80)	2" (3")	10	200	18	350	10	15.5
T750 230V*	0.75	5.4	750	50(80)	2" (3")	10	200	18	350	10	15.8
T1500 110V	1.5	26	1500	50(80)	2" (3")	16	243	21	670	10	19.3
T1500 230V	1.5	12	1500	50(80)	2" (3")	16	243	21	670	10	19.6
T1500 400V	1.5	4	1500	50(80)	2" (3")	16	243	21	670	10	19.3

\* Automatic versions available on request

Type	A	A1	A2	H	H1	H2	H1	H2
T400 110V	243	94	117	352	84	200	200	400
T400 230V	243	94	117	352	84	200	200	400
T750 110V	279	94	133	377	84	225	225	425
T750 230V	279	94	133	377	84	225	225	425
T1500 110V	313	107	155	446	94	308	294	494
T1500 230V	313	107	155	446	94	308	294	494
T1500 400V	313	107	155	446	94	308	294	494

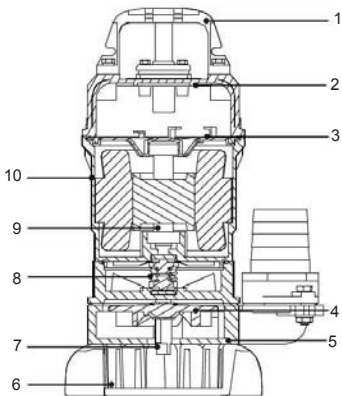

#### Parts & Material List

No	Part	Mtrl
1	Handle	Nylon 6
2	Motor Cover	ADC 12
3	End Bracket	SECC
4	Impeller	Urethane rubber
5	Pump Casing	FC-200
6	Strainer	PVC
7	Agitator	SMF 5030
8	Mech. Seal	Upper: CA/CE Lower: SIC/SIC
9	Shaft	SUS 410
10	Motor Housing	ADC 12

#### Performance Curve

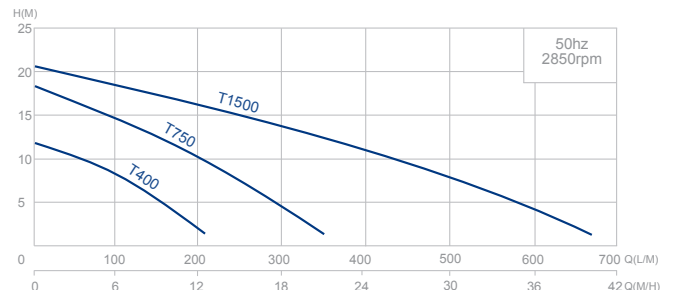

T-T PUMPS Ltd., Woore, Cheshire, CW3 9RU  
 Tel: 01630 647200 Fax: 01630 642100 www.ttpumps.com e-mail: response@ttpumps.com

\* The 1500 model pump must be operated in conjunction with a suitably rated transformer. Please contact T-T for more information.